

NEWS LETTER



SAN FERNANDO VALLEY R/C FLYERS, INC. LOS ANGELES, CALIFORNIA

VALLEY R/C FLYERS

c/o Don Butman, Editor
6161 Platt Ave.
Woodland Hills, Calif.
91364

WOODLAND HILLS, CALIF. 1



TO

SAN FERNANDO VALLEY R/C FLYERS, INC. LOS ANGELES, CALIFORNIA

PRESIDENT.....Frank Capan
VICE PRESIDENT.....Jim Oddino
SECRETARY.....Pat Leonard
TREASURER.....Larry Leonard
CONTEST DIRECTORS.....Dick Adams
 Willie Gardner

NEWSLETTER STAFF

EDITOR.....Don Butman
STAFF.....Loretta Hall
 Earl Harting
 Nate Rambo
 Woody Woodward
 Bob Upton

Permission to reprint granted, credit the Valley Flyers.

Meetings held on the 2nd Tuesday of the month at the Encino
Women's Club, 4924 Paso Robles Ave., Encino, California, at 8pm

PRESIDENT'S CORNER.....Frank Capan

Well the days keep going by, turning into months and before you know it Christmas Party time will be here with all the fun and frolics. Gee, I can hardly wait!

They said it couldn't be done, and you know what? They were right!! Not really though. Dick and Willie out did themselves by putting on that real fine Fun Frolic. I have never seen so many new faces at a contest and this is just great. This is really the way a Club should move in order to get the members to participate. You all know the only way a Club can continue is to enlist new members and also to have these new members participate in Club activities. There are many Clubs who have failed in this and they are not with us anymore!

I am sure we have enough officers in our Club so that any member who has any thoughts or views as to what we can do to improve our Club that he (or she) can let one of us know. If we can't continue to improve, then the only way we can go is down. Support your Club!!! Love thy neighbor and watch his frequency.

My thanks to all of you who came and tried and who no doubt enjoyed yourselves at the contest. To the others -- come on in, the water's fine!

Well we finally got our PA System and we'll have it at the meeting so you all can see it. Now all we need is an adding machine.

You know, this old Presidenting bit isn't as bad as I had thought it would be. It is actually painless. Don't get me wrong - I'm still hoping for the Christmas Party. Its just that I'm expecting a gift from Santa!

So keep those calls and letters coming. When???? We'll try to stagger through another meeting - keep smiling and may the good Lord bless all of you!

EDITOR'S ITEMS.....Don Butman

On behalf of the newsletter staff I want to thank all of you for the support in contributing articles and even saying nice things about the content of the newsletter. Just remember, if you have something that you would like to share with fellow Club Members write it up and "sock it to me"!

Read "Ross' Ramblings" in the Relay Chatter Newsletter (New England R/C Modelers) and discovered that he had a LOGICTROL I problem. Namely, no control while flying at 200 feet in 40° F. weather! In desperation he turned off the transmitter in an effort to make it "fail safe" but then couldn't tell if it did it or not.

After digging the model from a snow (what's that?) bank he shipped the radio gear all the way to EK Products in TEXAS for repair. It now has more than 12 feet range, without antenna, at 24° F.! Brrrrr!

We are luckier here without a doubt, since our weather is usually more temperate than New England's and LOGICTROL Service is no further than Woodland Hills! For me that's only a ½ block walk to "Salddino's", er... "Oddinski's", er... "O-S", oh well, just ask for either Bill Salkowski or Jim Oddino and they'll take care of your LOGICTROL problems.

PRESIDENT'S CORNER.....Frank Capan

Well the days keep going by, turning into months and before you know it Christmas Party time will be here with all the fun and frolics. Gee, I can hardly wait!

They said it couldn't be done, and you know what? They were right!! Not really though. Dick and Willie out did themselves by putting on that real fine Fun Frolic. I have never seen so many new faces at a contest and this is just great. This is really the way a Club should move in order to get the members to participate. You all know the only way a Club can continue is to enlist new members and also to have these new members participate in Club activities. There are many Clubs who have failed in this and they are not with us anymore!

I am sure we have enough officers in our Club so that any member who has any thoughts or views as to what we can do to improve our Club that he (or she) can let one of us know. If we can't continue to improve, then the only way we can go is down. Support your Club!!! Love thy neighbor and watch his frequency.

My thanks to all of you who came and tried and who no doubt enjoyed yourselves at the contest. To the others -- come on in, the water's fine!

Well we finally got our PA System and we'll have it at the meeting so you all can see it. Now all we need is an adding machine.

You know, this old Presidenting bit isn't as bad as I had thought it would be. It is actually painless. Don't get me wrong - I'm still hoping for the Christmas Party. Its just that I'm expecting a gift from Santa!

So keep those calls and letters coming. When???? We'll try to stagger through another meeting - keep smiling and may the good Lord bless all of you!

EDITOR'S ITEMS.....Don Butman

On behalf of the newsletter staff I want to thank all of you for the support in contributing articles and even saying nice things about the content of the newsletter. Just remember, if you have something that you would like to share with fellow Club Members write it up and "sock it to me"!

Read "Ross' Ramblings" in the Relay Chatter Newsletter (New England R/C Modelers) and discovered that he had a LOGICTROL I problem. Namely, no control while flying at 200 feet in 40° F. weather! In desperation he turned off the transmitter in an effort to make it "fail safe" but then couldn't tell if it did it or not.

After digging the model from a snow (what's that?) bank he shipped the radio gear all the way to EK Products in TEXAS for repair. It now has more than 12 feet range, without antenna, at 24° F. ! Brrrrr!

We are luckier here without a doubt, since our weather is usually more temperate than New England's and LOGICTROL Service is no further than Woodland Hills! For me that's only a ½ block walk to "Salddino's", er... "Oddinski's", er... "O-S", oh well, just ask for either Bill Salkowski or Jim Oddino and they'll take care of your LOGICTROL problems.



GOODYEAR RACING

APRIL 21, 1968 (SUNDAY) 8:30

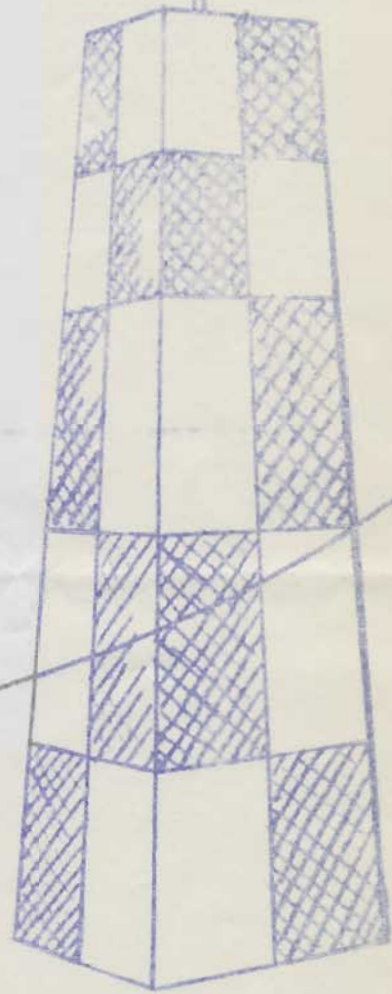
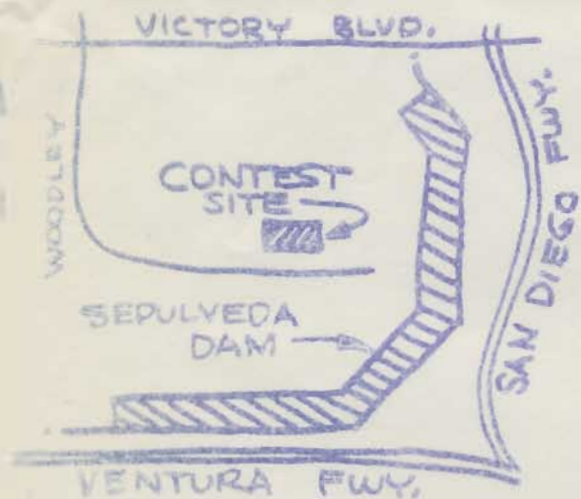

- * AMA SANCTION
- * 289 ENTRY FEE
NMPRA (AMA) RULES WILL BE STRICTLY ENFORCED
- * AMA - FCC AND NMPRA LICENSE REQUIRED
- * TROPHIES TO THIRD - MERCHANDISE TO FIFTH
- * CONTEST DIRECTOR - BOB UPTON
2179 MAYCOURT, SANTA SUSANA
PHONE 213-684-0847

I was asked to report on the field happenings. I went out to the Basin to see the happenings. I saw equestrians, dogs, birds, gophers, trees and toy airplanes flying. Not a happening in sight!

I asked one of the flyers, "What happened to the happening?". He said, "What happened?". I said, "No, not 'What happened', where is the happening?". He replied that he just got there and something was about to happen! Another chap heard this exchange and ran up to ask what happened. He wanted to be a witness. I told him, "Nothing happened; I had been told that there was to be a happening here". He advised me to go to Haight Ashburry or Berkeley as nothing ever happens around here.

By this time I was completely confused and was about to head for the nearest bar when, CRASH!!!!, toy airplane pieces all over the place! The owner yelled a few fitting phrases and finished with, "If that ever happens again I'll wrap this transmitter around his neck!" It finally came out that some one had turned a radio on on the frequency his set uses. This has disastrous results.

I called an immediate pow wow to learn of other problems that face the average R/C flyer.

Great Scott, do we have problems. I made notes of the various complaints and retired to my lair to solve them. I had the afternoon free so it was not an imposition.

Well sir, I solved them, one and all. Some do need more development work but then I'm not going to do everything. Some do have only local appeal, but this is reported to be the R/C center of the world. Perhaps they would catch on elsewhere.

Solutions (some are pictured to clarify)

1. A decal saying, "Love Gabby Frank" which when the words "Glitch, Glitch, Glitch" are said change into, "Help stamp out reeds".
2. Real airplanes for the "Model cities program".
3. Water proof shoes for those that panic easily.
4. A kit for crashes containing, olives, tooth picks and a pill which when added to your left over fuel turns it into a giant martini.

over

I was asked to report on the field happenings. I went out to the Basin to see the happenings. I saw equestrians, dogs, birds, gophers, trees and toy airplanes flying. Not a happening in sight!

I asked one of the flyers, "What happened to the happening?". He said, "What happened?". I said, "No, not 'What happened', where is the happening?". He replied that he just got there and something was about to happen! Another chap heard this exchange and ran up to ask what happened. He wanted to be a witness. I told him, "Nothing happened, I had been told that there was to be a happening here". He advised me to go to Haight Ashburry or Berkeley as nothing ever happens around here.

By this time I was completely confused and was about to head for the nearest bar when, CRASH!!!!, toy airplane pieces all over the place! The owner yelled a few fitting phrases and finished with, "If that ever happens again I'll wrap this transmitter around his neck!" It finally came out that some one had turned a radio on on the frequency his set uses. This has disastrous results.

I called an immediate pow wow to learn of other problems that face the average R/C flyer.

Great Scott, do we have problems. I made notes of the various complaints and retired to my lair to solve them. I had the afternoon free so it was not an imposition.

Well sir, I solved them, one and all. Some do need more development work but then I'm not going to do everything. Some do have only local appeal, but this is reported to be the R/C center of the world. Perhaps they would catch on elsewhere.

Solutions (some are pictured to clarify)

1. A decal saying, "Love Gabby Frank" which when the words "Glitch, Glitch, Glitch" are said change into, "Help stamp out reeds".
2. Real airplanes for the "Model cities program".
3. Water proof shoes for those that panic easily.
4. A kit for crashes containing, olives, tooth picks and a pill which when added to your left over fuel turns it into a giant martini.

over

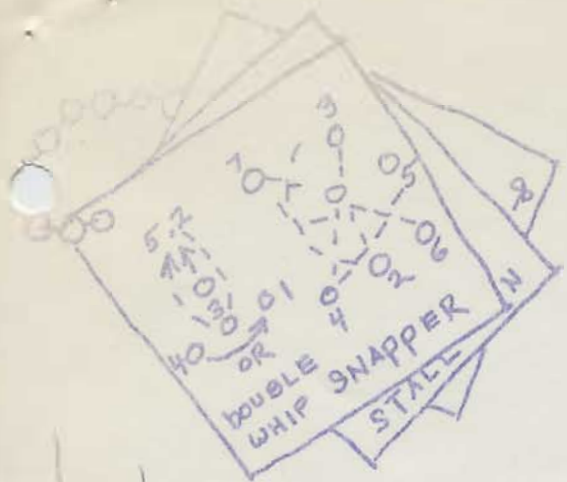

Maneuver templates for novice flyers ala Arthur Murray!

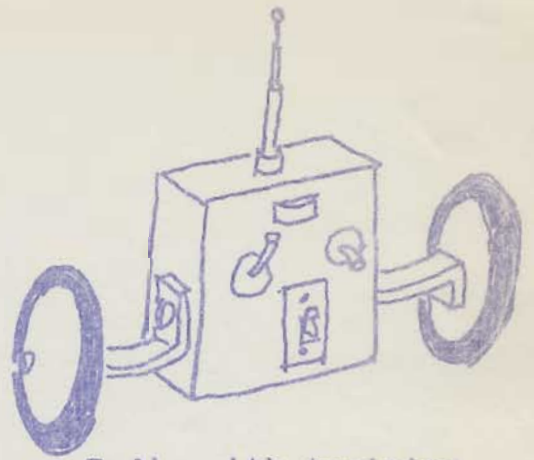

Radio with training wheels for new flyers!

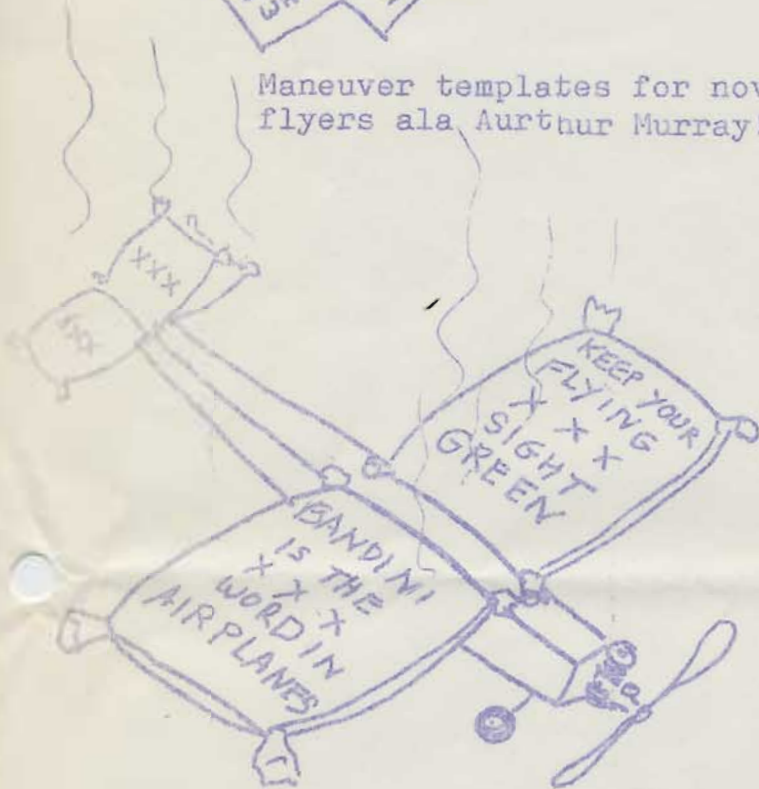

Toy airplane that turns into fertilizer 5 min's after a crash!

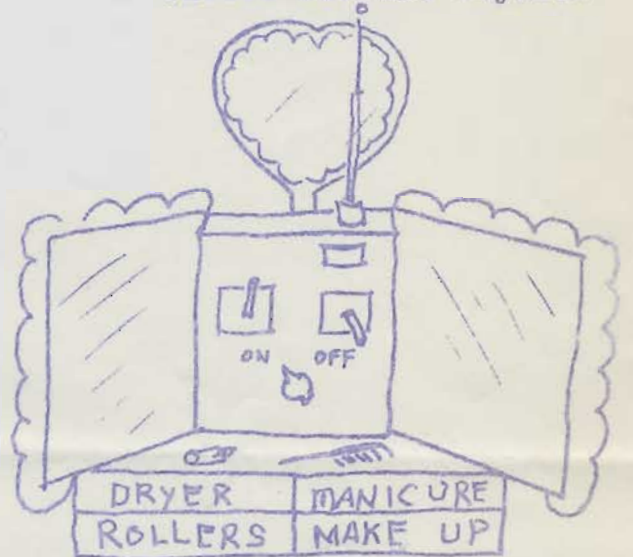

Radio set for women flyers

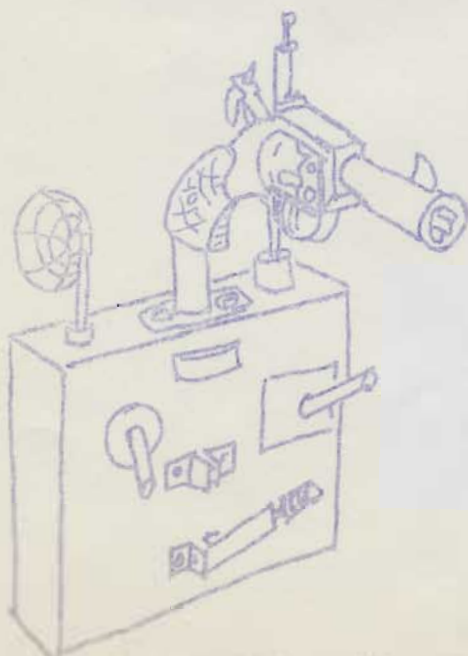

Radio that liquidates the person who turns it on if another trans. is on!

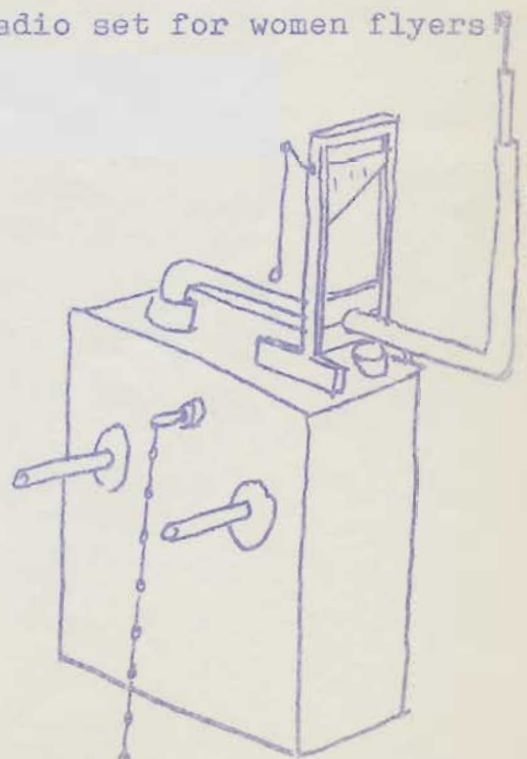

A trans. that self-destructs 5 sec's after a crash!

CONTEST CALCULATIONS.....Nate Rambo

FUN CONTEST

The VF Fun Contest was held at the Basin Sunday the 24th of March. I'm sure that most Club members turned out. But for those who didn't, here are a few words.

Everyone had a chance at each of three "Events".

EVENT #1 - Take off with a crepe paper streamer hooked loosely somewhere on the model. Turn or stall to drop the streamer at altitude. Try to cut it on the way down!

EVENT #2 - Take off with a doughnut speared somewhere on the model. Maneuver so as to drop the doughnut in the circle. ("2 chances)

EVENT #3 - Fly as long as possible on 2 ounces of fuel.

Well to say that everybody had fun is an understatement. I think all the non-contest types turned out and really excelled. The whole Club is indebted to our Contest Directors, Willie Gardner and Dick Adams for "throwing" this contest. I'm sure we also thank the many helpers who also officiated.

PYLON

A Goodyear and Open Pylon Contest was held on March 23 & 24 by the San Gabriel Valley R/C Society. Flying was at the Whittier Narrows Field.

Fifteen Goodyear and 24 Open Pylon Contestants turned out to compete. The prizes consisted of some nice merchandise, tools, kits, etc. A trophy was given for the best aircraft which was won, very deservedly, by Jack Stafford with his beautiful new Cosmic Wind (see Jack's new kit). Unfortunately, Jack later crashed this beautiful model due to RADIO trouble! His problems went from bad to worse when he later piled up his Mustang!!

The winners were as follows:

Goodyear	1st	Bob Upton / Marc Graham Racing Team Midget Mustang, K&B Front rotor
	2nd	Mr. Whoores Original Mustang
	3rd	Lou Zennicker / Mr. White Team Foster Rivets
Open	1st	Lou Stanley - Modified Barfly
	2nd	Chuck Hayes - Quick Fly
	3rd	Joe Vartarian - Lanier Saber

COMING CONTESTS

21 April	Sepulveda Basin	Goodyear
27-28 April	Phoenix	Goodyear
4-5 May	Turlock	Goodyear, 600 and Open

Don Baker

A FEW THOUGHTS ON SCALE MODEL
CONSTRUCTION

OR

WHY DID I EVER START THIS

Wings

Most scale wings have too many ribs. A good substitute for cutting ribs is to make a sheeted wing and apply $1/8$ " masking tape over the sheeting. The scale rib spacing etc. can easily be duplicated and you have a much stronger wing to boot. Cover over the taped wing with silk-span, dope and paint and it looks very realistic.

A very light and strong wing can be made by using 5" or 6" rib spacing and $1/8 \times 1/4$ stringers on edge span-wise on 2" centers, $1/4 \times 1/4$ leading edge and $1/2$ " trailing edge stock. This view of a rib may explain it more clearly.

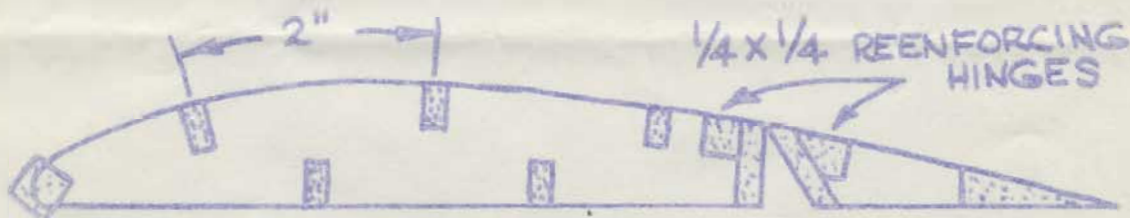

Stagger upper and lower stringers so as not to cut away too much rib at any one location. Basic frame is very flimsy but becomes very strong when sheeting is applied. Sheeting can be glued on with contact cement. Just apply enough coats to get a shiny surface, but be careful when applying the sheeting as you will have only one "shot." Any mistakes and you might as well junk it and start all over.

No dihedral braces are necessary if the panels are butt joined and 3" or 4" fiberglass tape is epoxied over the joint.

Ailerons may be cut out after wing panels are sheeted. Allow $1/16$ " for hinge and $1/8$ " on wing and $1/8$ " on ailerons for facing with $1/8$ " sheet, of course, all aileron bell-cranks and push-rods must be installed before final sheeting is put in place.

Aluminum Landing Gear, etc.

Cabin struts, landing gear struts and inter-plane struts may be hand sawed out of 1/8" aluminum sheet. Select aluminum that is fairly hard. Aluminum tabs are built into the fuselage and wings, and the struts are bolted on using #8 or #10 Nylon bolts. These will shear on a cart-wheel or crash and minimize the damage. The tabs can be made out of thinner stock, 1/6" or less. Tabs in the wings should be bolted and epoxied to plywood ribs. If you don't have a hand-saw, a sabre-saw with a metal cutting blade works just fine.

Cowlings

Cowlings of the round WWI type are built like a drum. Make the rear ring of 1/8" ply and the front ring of 1/4" balsa. The connecting spacers are of 1/8 x 1/4 balsa or spruce. The basic frame is sheathed with 1/8" balsa (soft) or two layers of 1/16 balsa. After sheathing the balsa blocks are glued to the front and sanded to the proper curve. The following illustration should clarify the procedure

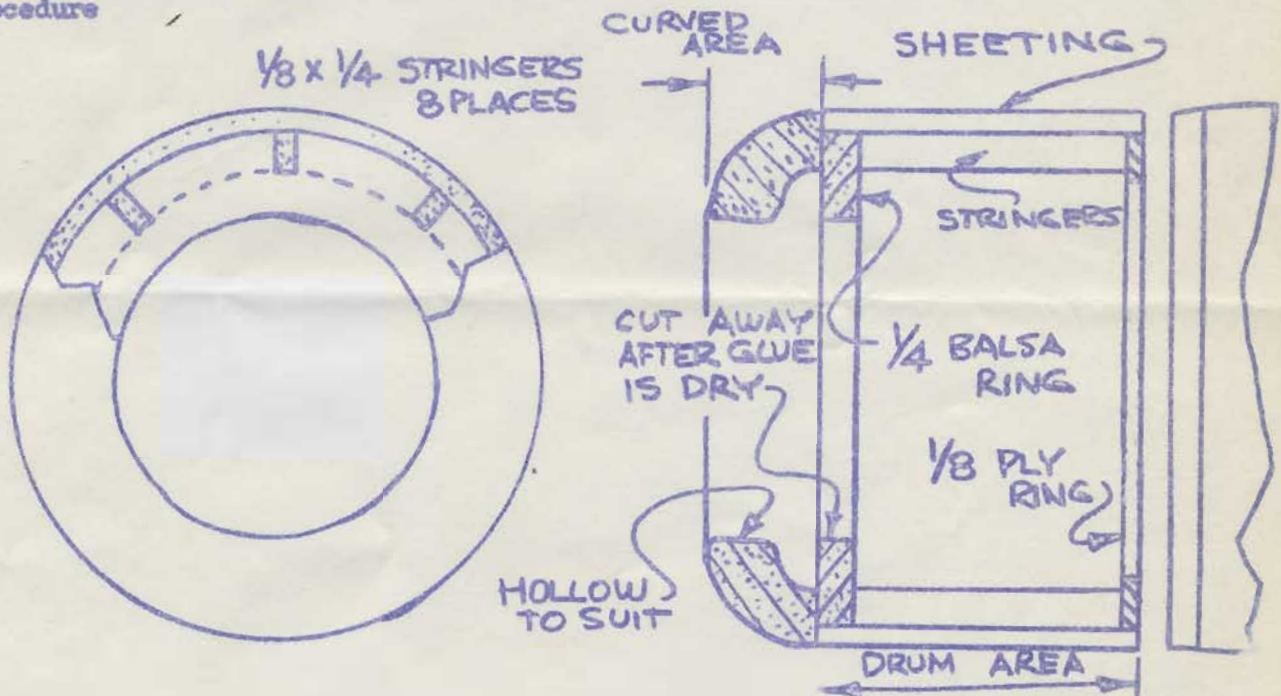

The center of the 1/8 ply ring is cut away so as to allow the cowl to slip over the engine. The cowl is held on with bolts and blind-nuts or sheet metal screws through the 1/8 ply ring into the fire wall. Access to these bolts is from the front of the cowl with a long screw driver.

Enough of this for now, get busy and build a scale model. Remember, if all else fails, buy a kit.

CONTEST WINNERS.....Willie Gardner

Now that the second successful contest is past history, Dick and I, as your contest Directors, are very happy over the results. This is specially true in Contestant turn-out and enthusiasm for Scale, the newest popularity event, and for the Fun Contest which drew praises and alltypes of good comments.

I must admit that there were a few trials and tribulations connected with the odd ball events at the Fun Contest, but with helpful hints from Various Contestants, everyone seemed happy and said they had loads offun.

At this time I wish to thank the following Hobby Shops for their contest donations which were in the form of merchandise goodies for the entrants. The HOBBY HOUSE (Art) and the FLITE HANGER (George) donated for the Scale Contest in February. WILSHIRE HOBBY (Hans) and LARRY'S HOBBY CENTER donated for the Fun Contest. Both Contests exceeded our wildest expectations, so please accept our apologies if you were one of the last entries and we were out of the goodies.

The next contest will be 21 April at the Basin and featuring Goodyear. Lets have another great turnout. We will appreciate all the help ypu can give us for this event.

By the way, we have some new ideas for the next Fun Contest so keep (or get) those ships in shape!

FUN CONTEST "REHASHED".....Dick Adams

For those of us that like to rehash old events and for those poor souls that did not make the Scene, here is the rehash of the Fun Type Contest of March 24th.

Twenty seven Hardy Souls did appear for the fun and games and that's just what it was too! Willie drew the events from the hat and away we went.

First trick out of the hat was the Streamer Cut. After some technical difficulties were worked out (the hard way by Dennis Dunn) all but one of us missed the darn thing at least a quarter of a mile! Carl Weyl scored the only "hit".

By the time the Donut Drop was started it was evident one flight line was not going to get the job done by dark so three lines were started. MAN! With three lines they dropped donuts all over the place. More hits were scored in the pits than in the target. Doug Kempf was the big man here. Young Doug scored two good hits with his donuts and coasted into the last event well in front.

The last event, time in the air on 2 oz. of fuel, was a gas (pardon the pun!). Would you believe 11minutes 08 seconds with a .60 powered Stinger by Dave Espinoza. Dave beat our Irv Weinberger's little H-Ray by 55 seconds. By the way, under who gives a damn information, average time in this event was 6 min 48 sec on 2 oz. of fuel. Who needs a 12 oz tank!

So here are the results:

1st - Doug Kempf
2nd - Roger Owen
3rd - Nate Rambo
4th - Carl Weyl
5th - Reed Packard
Worst Crash - Frank Capan
Oldest Entry - Reed Packard
Youngest Male - Doug Kempf
Youngest Female - Loretta Hall

UNCLASSIFIED ADS

2 - new Digimite servos, 1 center fail safe, 1 end fail safe
Sale or Trade

Digicon 4 Ch on 6 meters, complete outfit
Make Offer

Contact Walt Rutherford 348-5524

NEXT MEETING OF THE VALLEY FLYERS

Tuesday 9 April at 8 pm in the Encino Women's Club.
Bring your R/C models; a gallon of fuel given to the best one that
is brought by a member. Raffle 'n movies will round-out the affair!

SCALE FLY IN.....N.A.R. Flightmasters

14 April 1968, 8 am to 12 noon at the Sepulveda Basin.

YOU MAY FLY ANY

recognizable scale model
type of model - radio, control line,
gas or rubber powered, glider, jetax,
original, prefabbed or plastic

THERE WILL BE NO

scale judging or entry fees
proof of scale required
membership or licences required
age limits or events
limit to number of flights

Every flight receives a ticket. Prizes, trophies and merchandise will
be awarded by a drawing of tickets at 12:00 noon.
A flight is when the model rises from the ground and achieves a minimum
height of six feet.

A CONTESTANT'S COMMENTS.....Las Kesnar

I'm sure that all of us know that playing with Toy Airplanes is expensive. In fact, on some days at the Basin the costs go up drastically when we go down too fast and too hard. In spite of this we go back for more because this is fun?

Anyway on the 24th of March I decided to invest another Dollar in pursuit of said fun. I would like to say here and now that this was one of the best investments I've ever made. I entered our Club Fun Contest and in return received goodies certainly worth more than the entrance fee.

I would like to thank the Contest Directors, Willie and Dick, for a very exciting day. Comparable, I think,, to the day I tried to save Ken Hall's Airplane from crashing by using my transmitter while my plane flew away!

Thanks Dick, for putting my name first on the Contestant's list so everyone else could learn from my mistakes and improve their scores.

Special thanks to Willie for using Very Fresh donuts so the guy that hit my wing and Glen Jarvis' face didn't poke a hole in either!

Thanks also to both of the guys who were nice enough to score lower than me in the endurance contest so that I wouldn't be low man in all three events! When I went over to check the score sheet the highest number next to my name was either my age or AMA number!

Finally, thanks to the poor bombing of the Valley Flyers 20 or 30 spectators had free donuts with their lunch.

All in all this was a most enjoyable day and think that something as much fun as this contest should happen more often!